



AVANTAGES

- Size DN15...DN40
- Nominal flow 0.6...10 m³/h
- For horizontal or vertical mounting
- Compact meter with easy-to-read display
- No moving parts enable flow measurement at low pressure drops
- Back flow detection
- Available with M-Bus, pulse output or M-Bus and 2 pulse inputs
- 230 V power pack available as accessory

DESCRIPTION

Externally threaded, compact energy meters with built-in ultrasonic flow meter, intended for heating or cooling.

FONCTION

The menu system, available in the display, makes it possible to read a large number of parameters, such as heat and cold consumption, total energy spent on heating and cooling, temperatures along with current energy consumption. Installation is normally in the return pipe.

CONNEXION

The energy meter comes equipped with two PT1000 temperature sensors. The resistors for the sensors are composed of platinum and maintain a standard of DIN IEC 60751. The return temperature sensor is integrated into the flow meter while the supply temperature sensor is connected via a cable.

MONTAGE

The temperature sensor can be mounted directly in the media or in sensor pockets. The compact design of the energy meter allows it to be mounted even in narrow spaces.

More installation accessories are also available such as ball valves with installation point for a temperature sensor or pipe connection kits etc. See more under the heading Accessories.

FIABILITE

The meter offers reliable and accurate performance over long periods of measurement.

DESIGN

Due to the multiple combination options offered by its components, the meters can easily be adapted to suit a large number of individual requirements.

Models with M-Bus, pulse output or M-Bus + pulse input are available.

Energy meters with M-Bus have a default address of "0", which is not a valid primary communication address. This primary address can be changed by searching for secondary addresses (i.e. the ID number of the meter).

EXEMPLE INSTALLATION - CHAUFFAGE

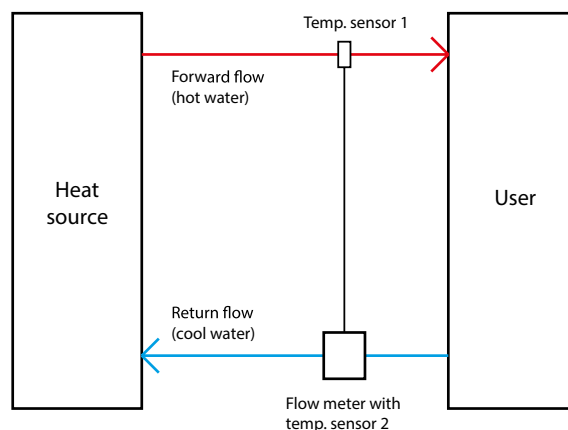



EXEMPLE INSTALLATION - CLIMATISATION

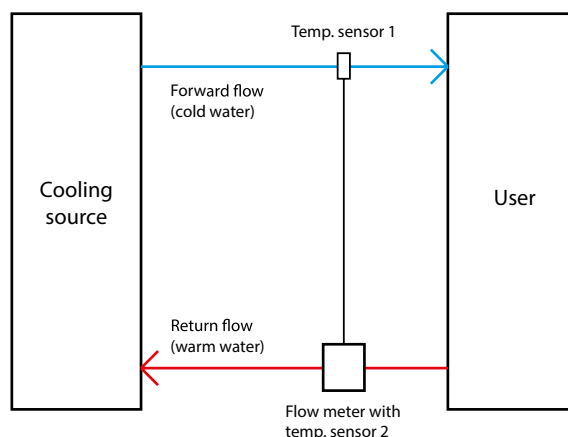

At first use, the installation position can be changed with the main button if forward flow installation is needed.

CARACTERISTIQUES TECHNIQUES - COMPTEUR

Power supply	Exchangeable 3 V lithium battery, estimated lifetime 10 years. 230 V power pack available as accessory.
Temperature range, heating	0...150 °C
Temperature range, cooling	0...50 °C
Temperature difference range, heating	3...100 K
Temperature difference range, cooling	-3...50 K
Temperature resolution	0.01 °C
Ambient temperature	5...55 °C
Storage temperature	1...60 °C
Ambient humidity	Max. 95% RH
Protection class	IP65
Calculation of heat from K	$\Delta T > 0.05$ K
Calculation of cooling from K	$\Delta T < -0.05$ K
Measurement cycle, temperature	2...60 s
Measurement cycle, temperature (using 230 V power pack)	2 s
Measurement cycle, flow	2 s
Data storage	Non-volatile memory
Interfaces	M-Bus, pulse output or M-Bus with 3 pulse inputs
Reading dates	15 monthly and semi monthly values via display, 24 monthly and semimonthly values via optical interface or M-Bus. Annual billing date selectable.
Display	LCD, 8 digits + special characters
Display units	MWh, kW, GJ, m ³ , m ³ /h (kWh, GJ, l, l/h, MW, MMBTU, Gcal), 3 decimal places. The unit for energy consumption can only be set while the energy consumption is ≤ 10 kWh.
Mechanical class	Class M1 (MID: 31.03.2004 annex I)
EMC	Class E2 (MID: 31.03.2004 annex I)
Environmental class	C (EN 1434)
Dimensions, calculator (WxHxD)	110 x 75 x 34.5 mm
Cable length (measuring unit)	85 cm

CARACTERISTIQUES TECHNIQUES - CAPTEUR DE TEMPERATURE

Cable length	1.5 m (the other temperature sensor is integrated into the flow meter)
Sensor element	PT1000, DIN IEC 60751
Diameter, sensor	5 mm
Installation	Direct (see the accessories section) or indirect in a temperature sensor pocket per EN1434
Temperature sensor requirements, heat meter	EU (MID) identification on the temperature sensors
Temperature sensor requirements, cooling meter	National German approval as a temperature sensor for cooling meters. Requirements in other countries may be different.





CARACTERISTIQUES TECHNIQUES - DEBITMETRE

Connection	Threaded according to ISO 228/1
Pressure rating	PN16
Media	Water
Mounting position	Horizontal or vertical
Point of installation	Return flow (if forward flow installation is needed, the installation position can be changed with the main button)
Temperature range	15...90 °C
Measuring principle	Ultrasonic; time-of-flight
Dynamic range q1/qp	1:100 (1:50 for qp0.6)
Accuracy according to MID	Class 2
Recommended minimum system pressure	1 bar (to avoid cavitation problems)

MODELES

Article	Nominal diameter	Nominal flow, qp	Maximum flow, qs	Minimum flow, qi	Low flow threshold	Pressure drop at qp	Pressure drop at qs
SSU15-0.6...	DN15	0.6 m3/h	1.2 m3/h	12 l/h	6 l/h	0.03 bar	0.13 bar
SSU15-1.5...	DN15	1.5 m3/h	3.0 m3/h	15 l/h	6 l/h	0.21 bar	0.85 bar
SSU20-2.5...	DN20	2.5 m3/h	5.0 m3/h	25 l/h	12 l/h	0.115 bar	0.46 bar
SSU20-3.5...	DN20	3.5 m3/h	7.0 m3/h	35 l/h	14 l/h	0.21 bar	0.885 bar
SSU25-3.5...	DN25	3.5 m3/h	7.0 m3/h	35 l/h	14 l/h	0.21 bar	0.885 bar
SSU25-6.0...	DN25	6.0 m3/h	12 m3/h	60 l/h	30 l/h	0.20 bar	0.80 bar
SSU40-10...	DN40	10.0 m3/h	20 m3/h	100 l/h	50 l/h	0.24 bar	0.96 bar



This product carries the CE-mark.

ODRE DE SELECTION

Options	SSU...
Flow (thread on meter body) (DN) (length of flow meter)			
0.6 m3/h (G3/4") (DN15) (110 mm)	SSU15-0.61		
1.5 m3/h (G3/4") (DN15) (110 mm)	SSU15-1.5		
2.5 m3/h (G1") (DN20) (130 mm)	SSU20-2.5		
3.5 m3/h (G1") (DN20) (130 mm)	SSU20-3.5		
3.5 m3/h (G1 1/4") (DN25) (150 mm)	SSU25-3.5		
6.0 m3/h (G1 1/4") (DN25) (150 mm)	SSU25-6.0		
10.0 m3/h (G2") (DN40) (200 mm)	SSU40-10.0		
Type of measurement and installation point			
Heating, installation of flow meter in return pipe (MID approval)		-HR	
Cooling ² , installation of flow meter in return pipe		-CR	
Communication interface			
M-Bus			-M
M-Bus with 3 pulse inputs ³			-MPI
Pulse output for energy			-PO

1 0.6 is only available for heating, not for cooling

2 National German approval.

3 The standard setting for the pulse counters is 1 l/pulse. Please contact Regin if other values (10 l/pulse or 100 l/pulse) are needed.

If any further requirements or options are needed, for instance heating and cooling in combination, please contact Regin.

Example 1:

Desired application: Meter with 1.5 m3/h. Heating, installation in return pipe. M-Bus.

Resulting item ordering number: SSU15-1.5-HR-M

Possible accessories needed:

KH-3/4, 2 pcs, ball valve connection for both sides of the meter, alternatively brass fittings VSR-1/2

KH-S-3/4, 1 pc, ball valve with installation point for a temperature sensor in supply flow





ODRE DE SELECTION

Example 2:

Desired application: Meter with 3.5 m³/h, DN25. Cooling, installation in return pipe. M-Bus + pulse input.

Resulting item ordering number: SSU20-3.5-CR-MPI

Possible accessories needed:

KH-1¼, 2 pcs, ball valve connection for both sides of the meter or brass fittings VSR-1

KH-S-1¼, 1 pc, ball valve with installation point for a temperature sensor in supply flow

ACCESSOIRES

Threaded fitting with coupling ring and gasket *

Article	Connection A	Connection B	Compatible with	Meter DN
VSR-1/2	G¾	R½	qp0.6/1.5 m /h3	15
VSR-3/4	G1	R¾	qp2.5/3.5 m /h3	20
VSR-1	G1¼	R1	qp3.5/6.0 m /h3	25
VSR-1 1/2	G2	R1½	qp 10 m /h3	40

* Either the brass threaded fittings or the ball valves are to be used on each side of the flow meter. 2 pcs are required for each meter



Ball valve with coupling ring and gasket *

Article	Connection A	Connection B	Compatible with	Meter DN
KH-3/4	Rp¾	G¾	qp0.6/1.5 m /h3	15
KH-1	Rp1	G1	qp2.5/3.5 m /h3	20
KH-1 1/4	Rp1¼	G1¼	qp3.5/6.0 m /h3	25
KH-2	Rp2	G2	qp10 m /h3	40

* Either the brass threaded fittings or the ball valves are to be used on each side of the flow meter. 2 pcs are required for each meter.

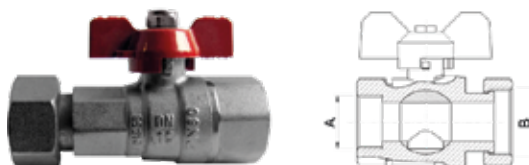

Ball valve with installation point for a temperature sensor (socket M10x1)

Article	Connection A	Compatible with	Meter DN
KH-S-3/4	G¾	qp0.6/1.5 m /h3	15
KH-S-1	G1	qp2.5/3.5 m /h3	20
KH-S-1 1/4	G1¼	qp3.5/6.0 m /h3	25
KH-S-2	G2	qp10 m /h3	40

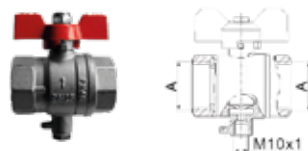

Supply flow adapter with gasket, for direct mounting of a temperature sensor in a T-piece

Article	Connection A
VAD-1/2	G½, M10x1
VAD-3/8	G3/8, M10x1





ACCESSOIRES (suite)

Threaded adapter to replace a flow meter temporarily or permanently

Article	Attacco A	Compatible with	Installation length	Meter DN
PS-110-3/4	G $\frac{3}{4}$	qp0.6/1.5 m ³ /h3	110 mm	15
PS-130-1	G1	qp2.5 m ³ /h3	130 mm	20
PS-150-1 1/4	G1 $\frac{1}{4}$	qp 3.5/6 m ³ /h	150 mm	25
PS-200-2	G2	qp 10 m ³ /h3	200 mm	40



Optical interface and read-out software

Article	Description
OPTO-CABLE-USB	Optocoupler with USB interface
OPTO-TOOL	Software device monitor



230 V power pack

Article	Description
POWERPACK-EM	230 V power pack
POWERPACK-EM-24	24 V AC power pack



Spare parts

BATTERY-EM - Battery



DIAGRAMME PERTE DE CHARGE

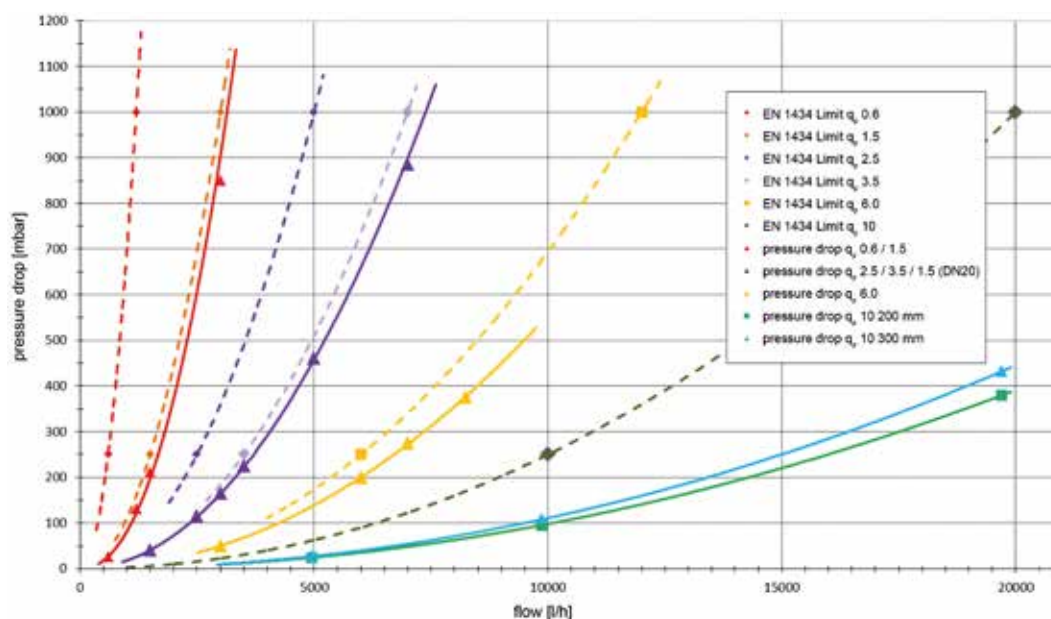



DIMENSIONS

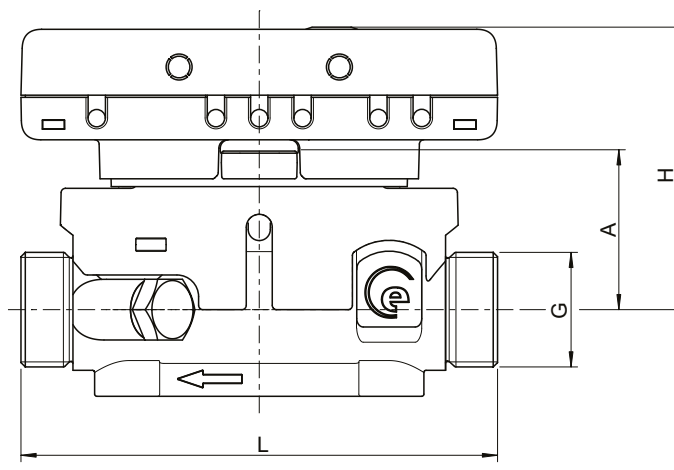

Qp (m3/h)	Nominal diameter	G (")	L	H	A
0.6	DN15	G3/4B	110	65	37
1.5	DN15	G3/4B	110	65	37
2.5	DN20	G1B	130	65	37
3.5	DN20	G1B	130	65	37
3.5	DN25	G1½B	150	65	37
6.0	DN25	G1½B	150	67.5	39.5
10.0	DN40	G2B	200	73	45

Measurements in mm unless otherwise specified.

